

# Clean Power: ALSTOM's Vision

Didier FAREZ  
Country President, Alstom in South Africa

December 2009

**ALSTOM**

Our Group: A major industry player

Why “Clean Power”?

A Pragmatic approach

Alstom Power Solutions

# Alstom Group

## Two sectors

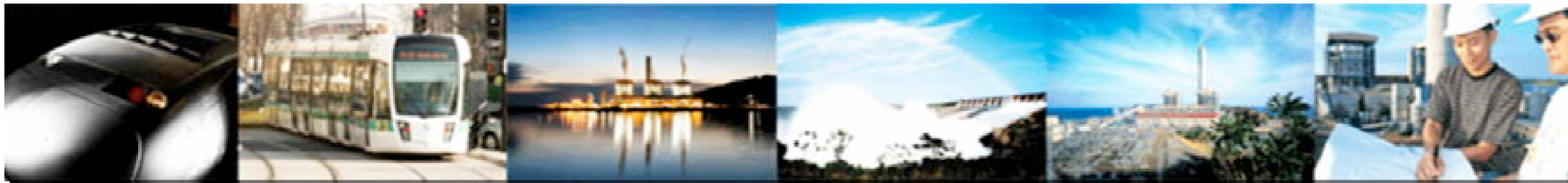
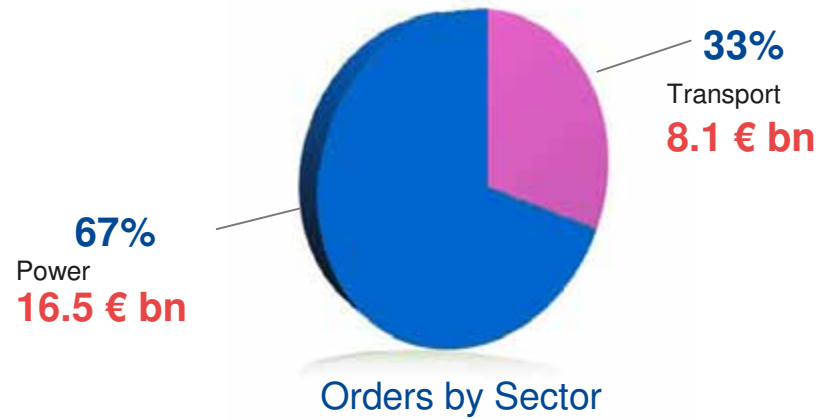

**N°1 worldwide**

in high speed  
and very high speed

integrated  
power plants

**N°1 worldwide in:**

hydro  
power\*

air quality  
control systems

services for  
electricity utilities

Source: Alstom 2008/09

\* through Alstom Hydro, a 50/50 joint venture between Alstom and Bouygues set up in 2006

# Alstom Group

81,700 employees in over 70 countries



Source: Alstom 2008

# Our projects:

Over 41 GW under execution

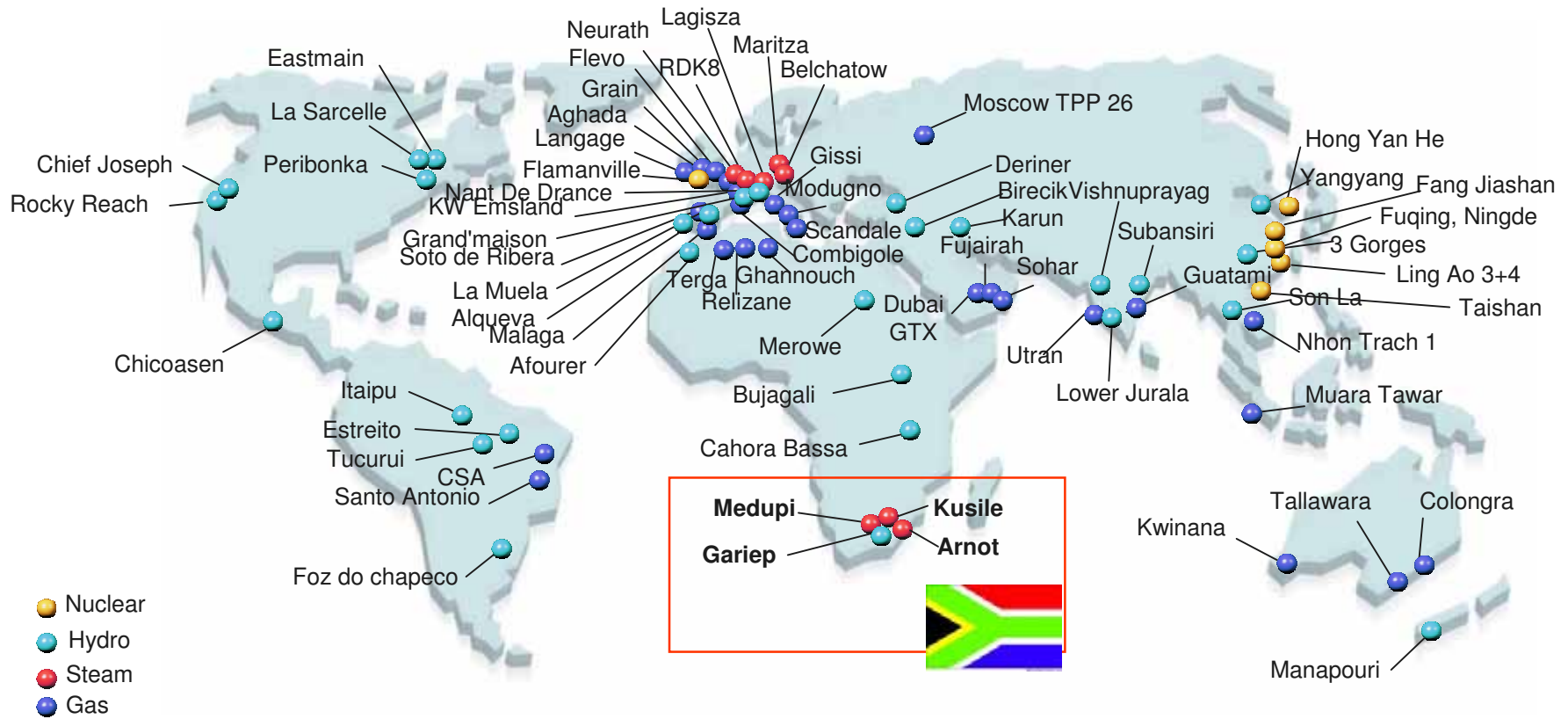

Our Group: A major industry player

Why Clean Power ?

A Pragmatic approach

Alstom Power Solutions

# Power generation market

Considerable growth in the last 50 years



Annual Orders [GW/y]

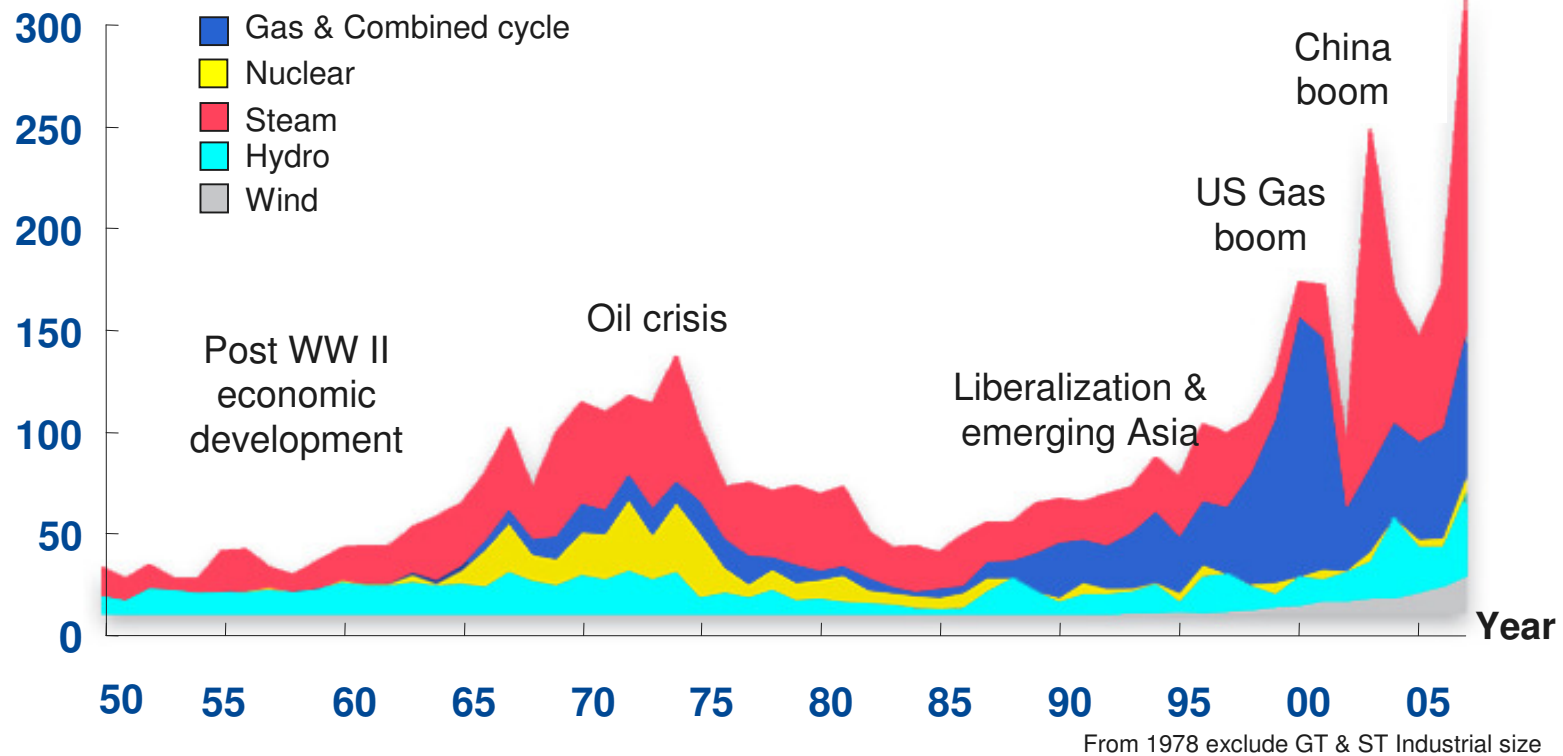

Considerable growth in the last 50 years

# New power plant per technology



Orders per technology in GW p.a

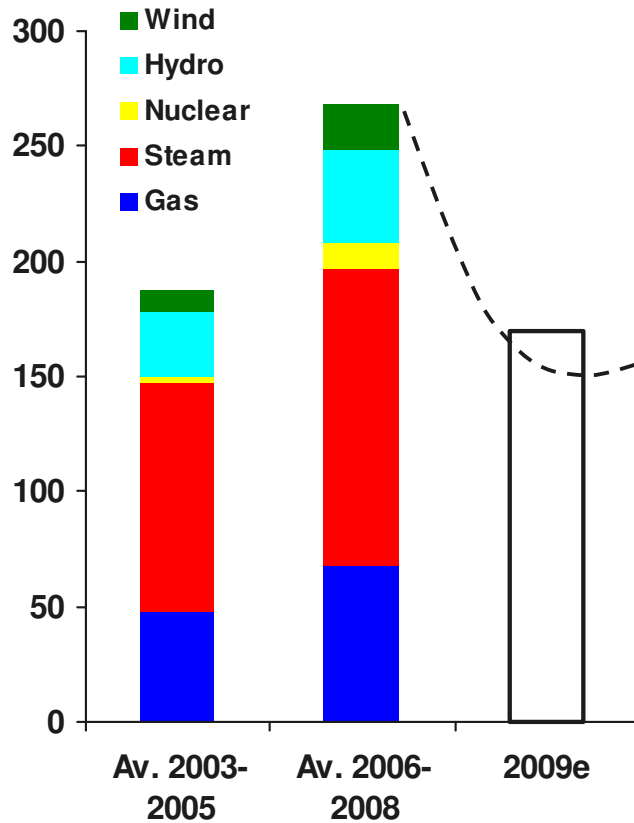

Long Term IEA scenarios towards 2030

Average gross capacity addition in GW p.a

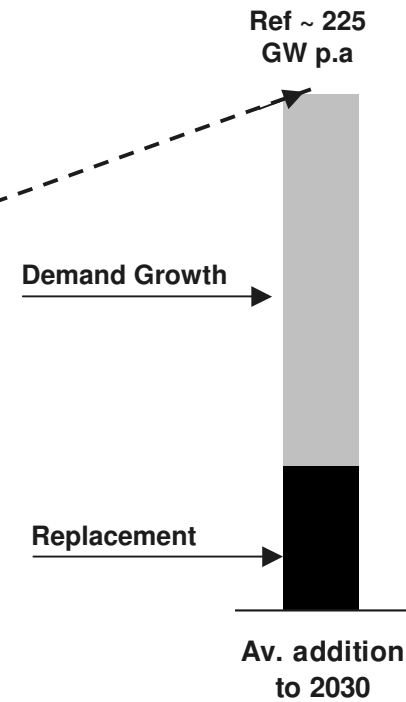

Source: Market until 2009e + replacement : ALSTOM

Long term demand growth: IEA ref scenario WEO 2006 / 2007 with 3.6% real PPP GDP growth (IB in 2030 is 8240 GW)

Short term drop, medium term sustained

# Power market trends



Large Scale	Large Scale	Small Scale	Gas turbine	Other Recovery Systems	Heat Exchangers	Electro- thermal conversion	Renewables	Nuclear Core Reactors	Plant Flex.	Energy Storage
■	■	■	■	■	■	■	■	■	■	■
■	■	■	■	■	■	■	■	■	■	■
■	■	■	■	■	■	■	■	■	■	■
■	■	■	■	■	■	■	■	■	■	■



- **Environment** is a key driver
- The **whole technological Portfolio** will be necessary
- The market demands **integrated solutions**
- More than 60% of the market will be in **Asia**

# Environment becoming the first driver

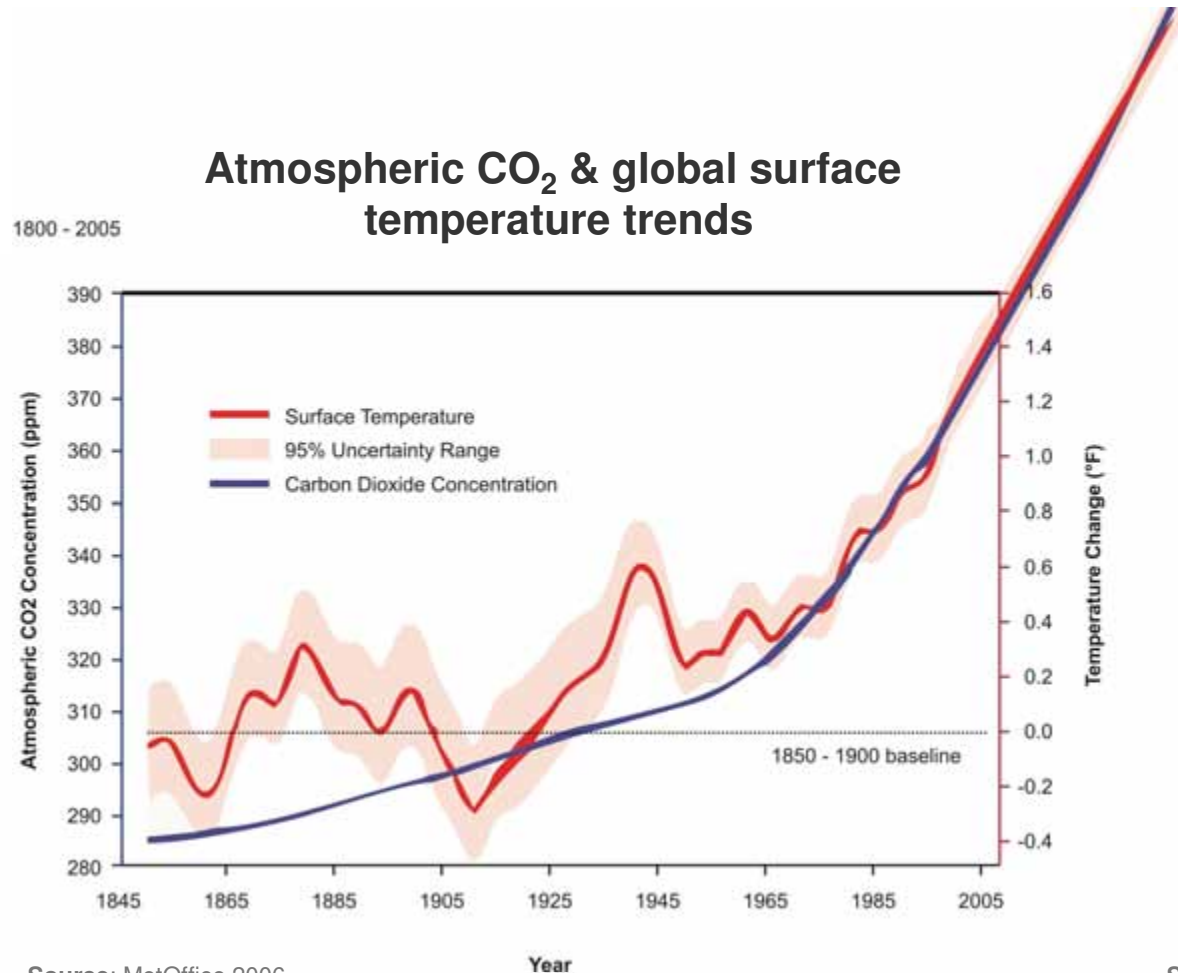

Source: MetOffice 2006

### CO<sub>2</sub> global emissions per sector

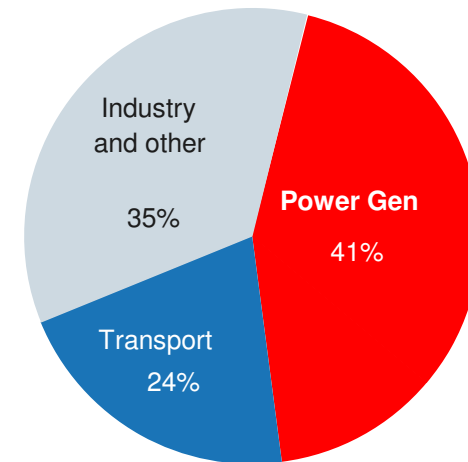

Source: International Energy Agency, "World Energy-Related CO<sub>2</sub> Emissions by Sector in the Reference Scenario," **World Energy Outlook 2008**

# Installed base Evolution

## Per technology



2008

2020

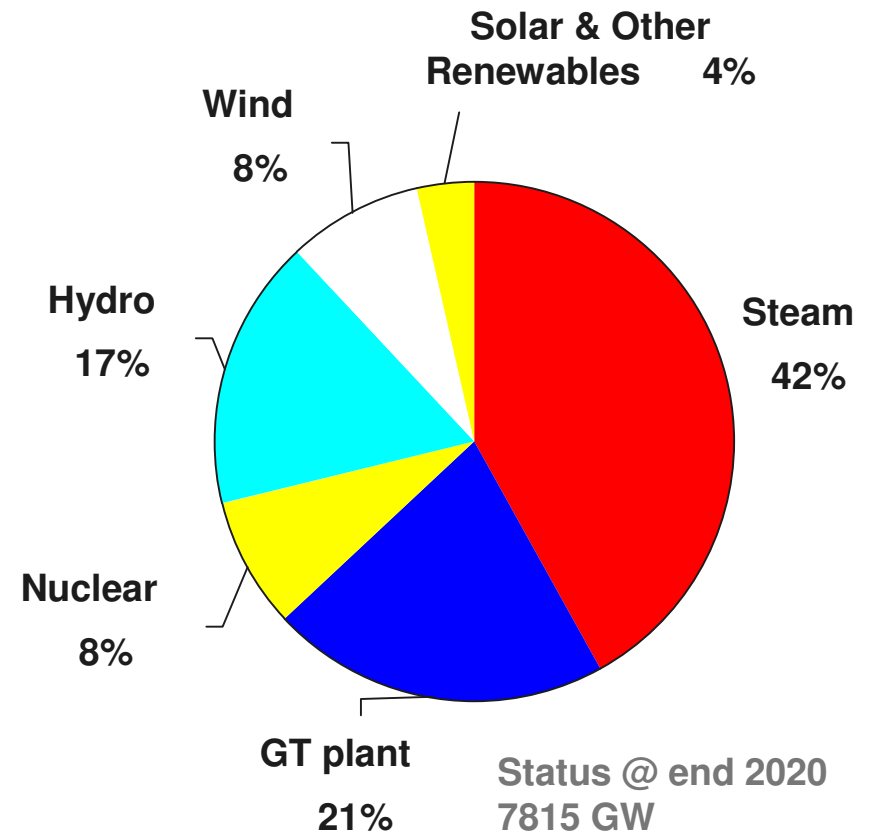
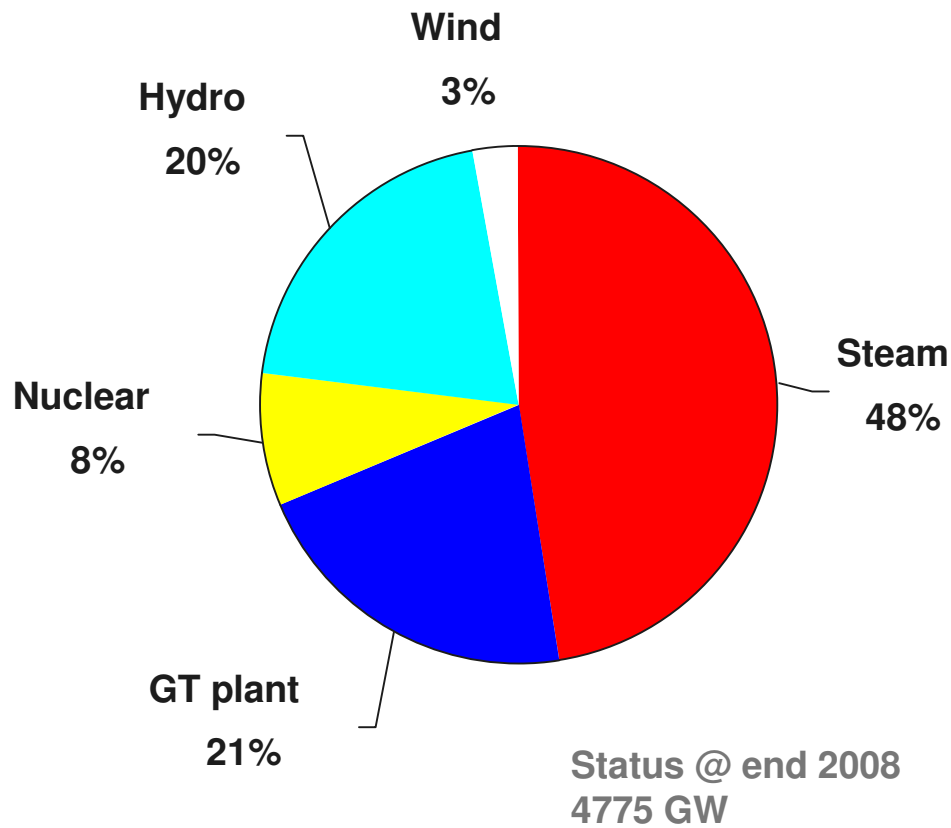

Our Group: A major industry player

Why Clean Power ?

A Pragmatic approach

Alstom Power Solutions

# Alstom CO<sub>2</sub> strategy



Alstom is the world leader in clean integrated solutions

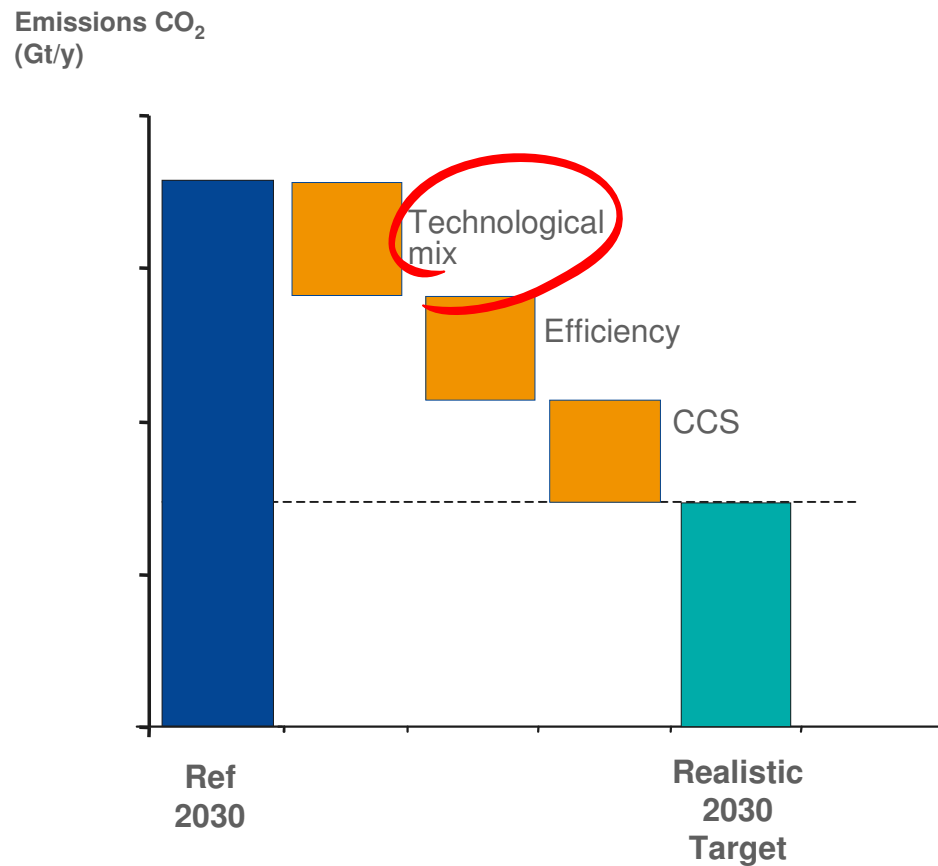

		N° 1 hydro
		Wind and geothermal
		N° 1 nuclear (conventional islands) & biomass
		Efficiency: Plant optimisation & retrofit
		First CO <sub>2</sub> capture demo plant in the world

# Alstom CO<sub>2</sub> strategy



Alstom is the world leader in clean integrated solutions

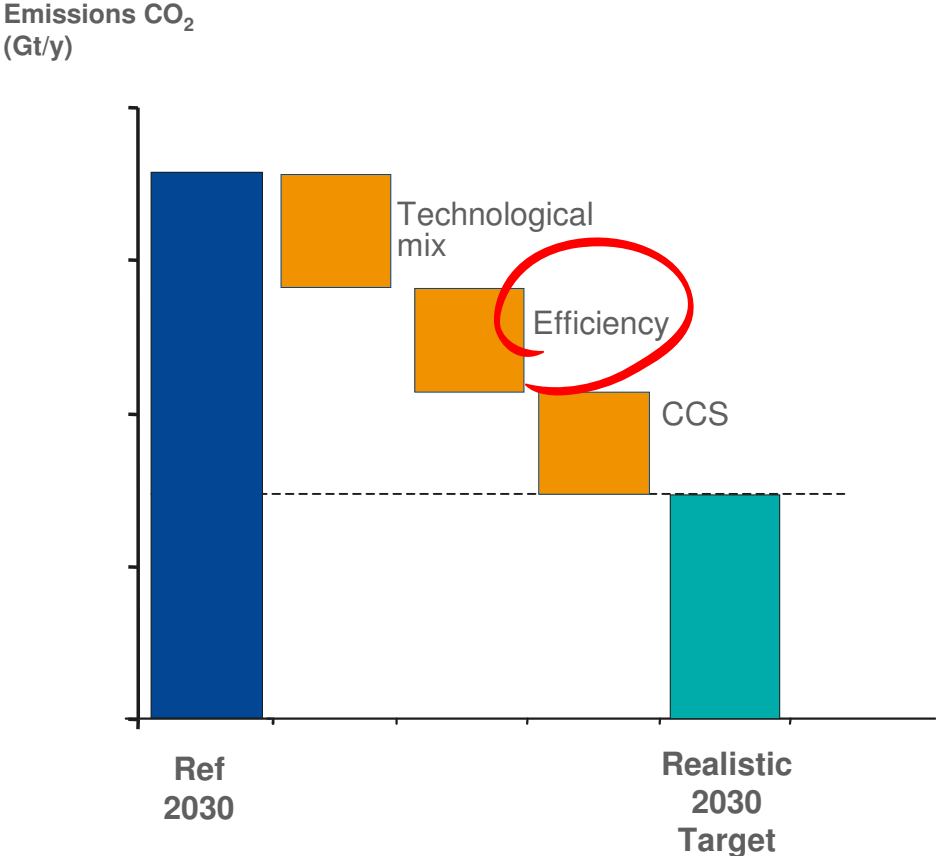

		N° 1 hydro
		Wind and geothermal
		N° 1 nuclear (conventional islands) & biomass
		Efficiency: Plant optimisation & retrofit
		First CO <sub>2</sub> capture demo plant in the world

# The efficiency challenge



Estimated average efficiency of coal installed base

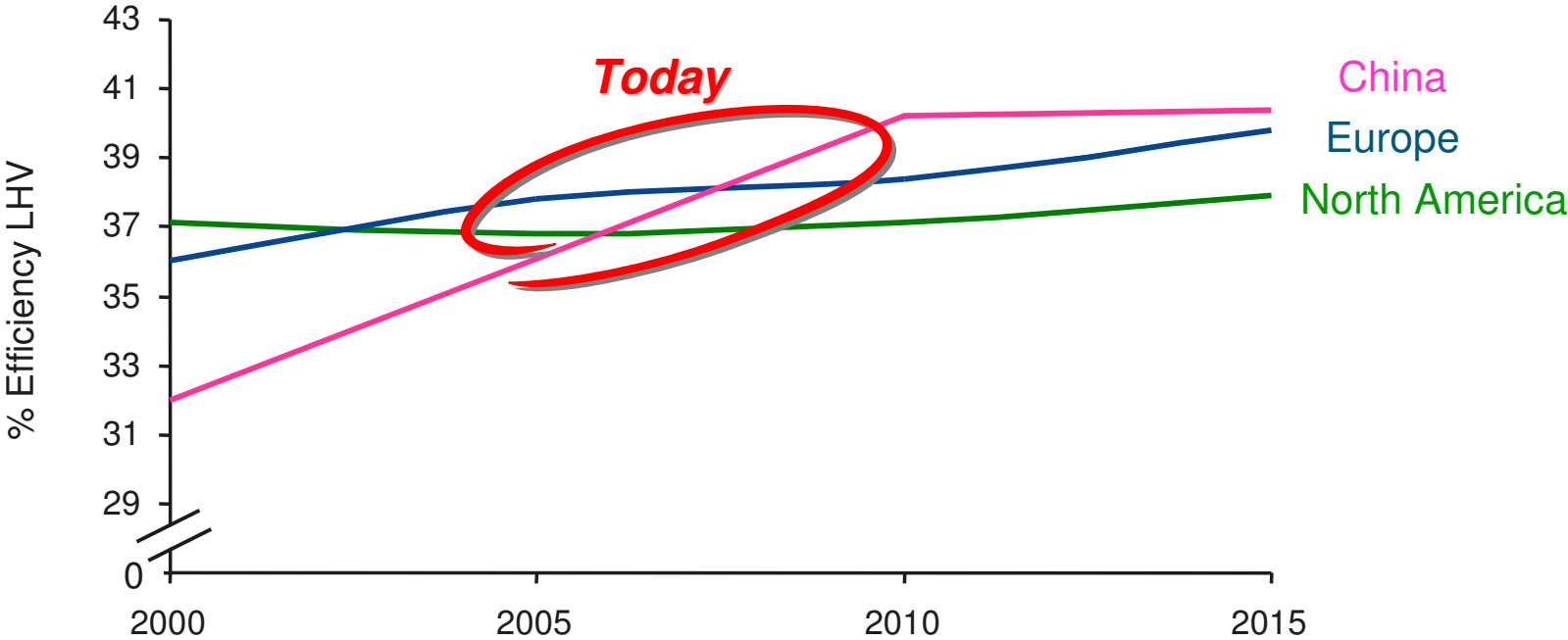

Source: Alstom, Vision 2030 Market Scenarios

# Production Efficiency



## New Plants



Coal: +20 p.p in efficiency saves 40% CO<sub>2</sub> emissions



Gas: +20 p.p in efficiency saves 33% CO<sub>2</sub> emissions

60% of the 2030 installed base still to be built

## Retrofit

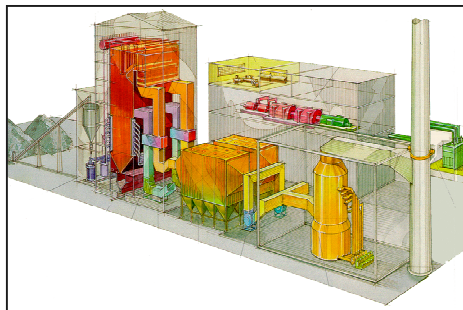

Plant Optimisation: -5% CO<sub>2</sub>

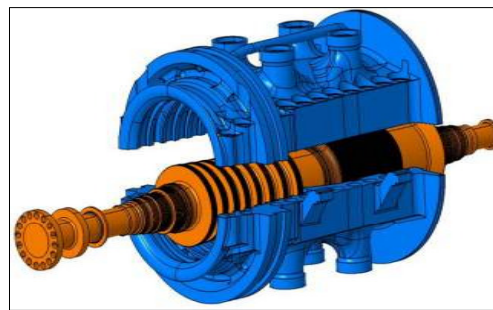

Turbine retrofit: -5% CO<sub>2</sub>

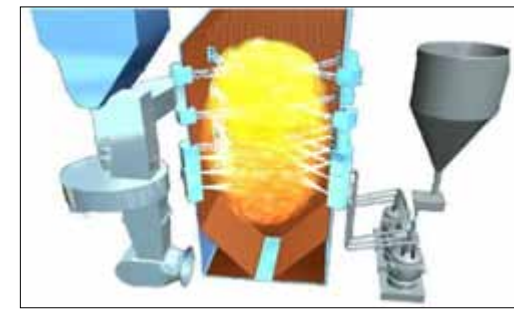

Boiler retrofit: -3% CO<sub>2</sub>

60% of Carbon emitted in 2030 will come from today's installed base

# Alstom CO<sub>2</sub> strategy



Alstom is the world leader in clean integrated solutions

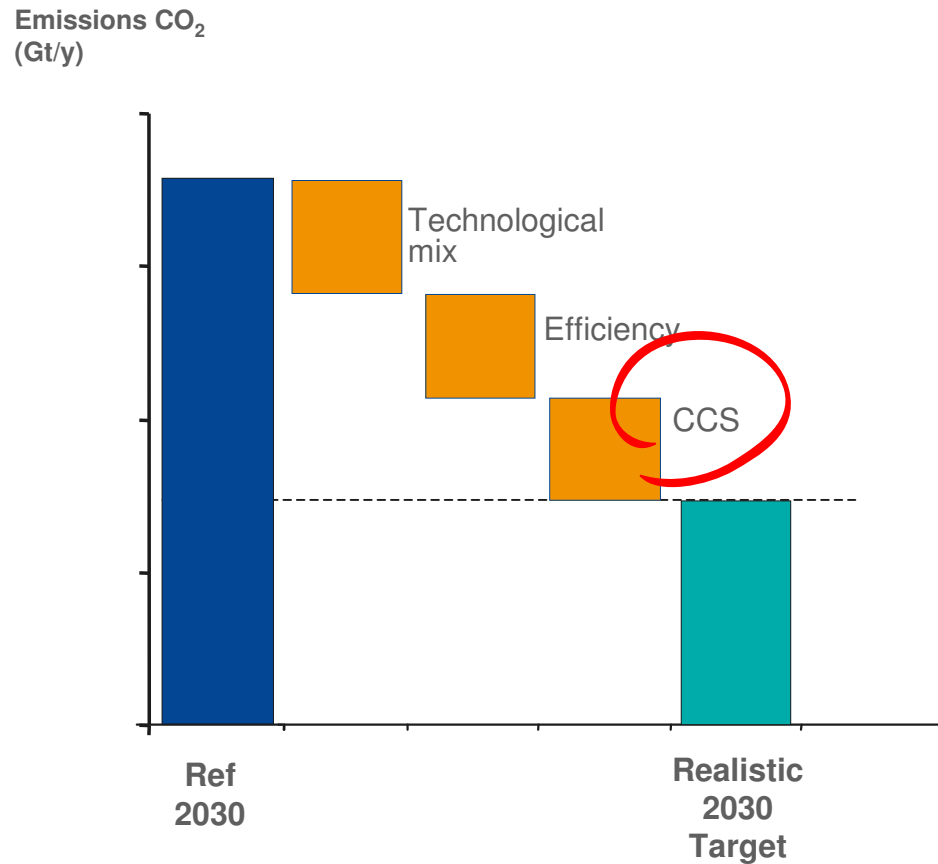

		N° 1 hydro
		Wind and geothermal
		N° 1 nuclear (conventional islands) & biomass
		Efficiency: Plant optimisation & retrofit
		First CO <sub>2</sub> capture demo plant in the world

# CO<sub>2</sub> Capture Solutions



## Power Plant with CO<sub>2</sub> capture

Post - combustion  
(New + retrofit)

Oxy - combustion  
(New + retrofit)

Pre-combustion  
(New only)

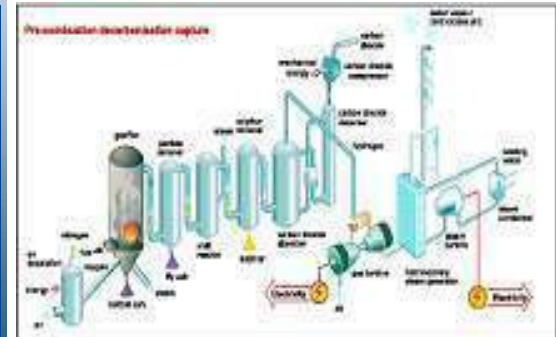
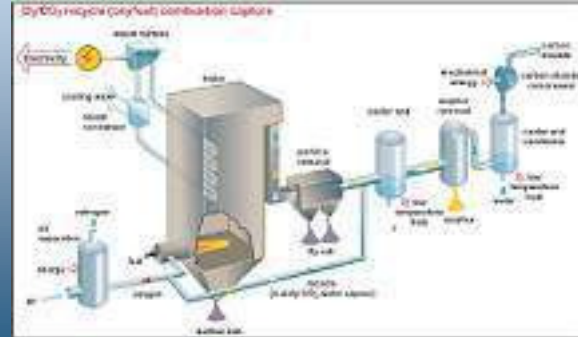

Solutions developed by ALSTOM

CCS must adapt on installed base

Our Group: A major industry player

Why Clean Power ?

A Pragmatic approach

Alstom Power Solutions

Tidal

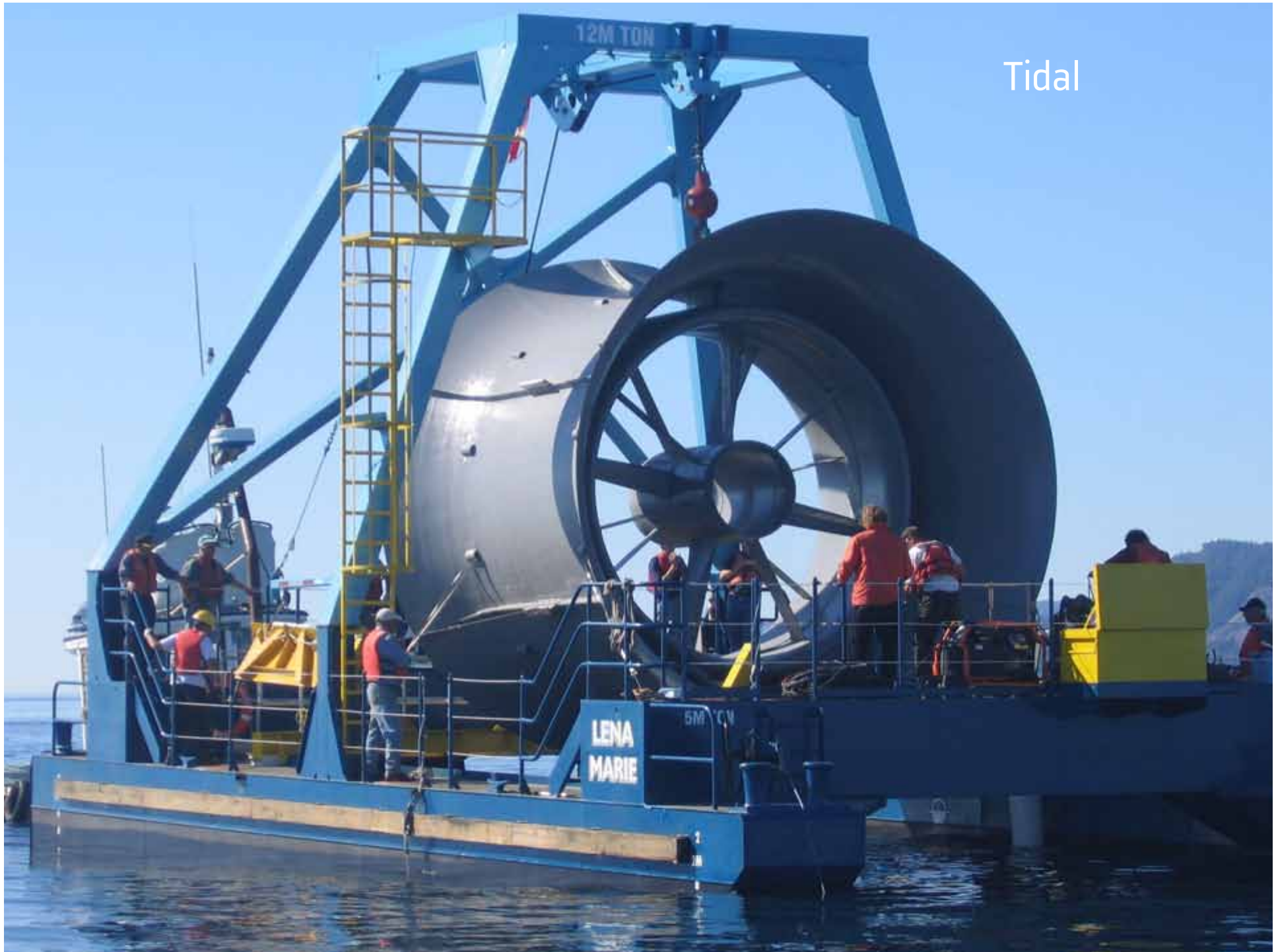

Wind



Nuclear

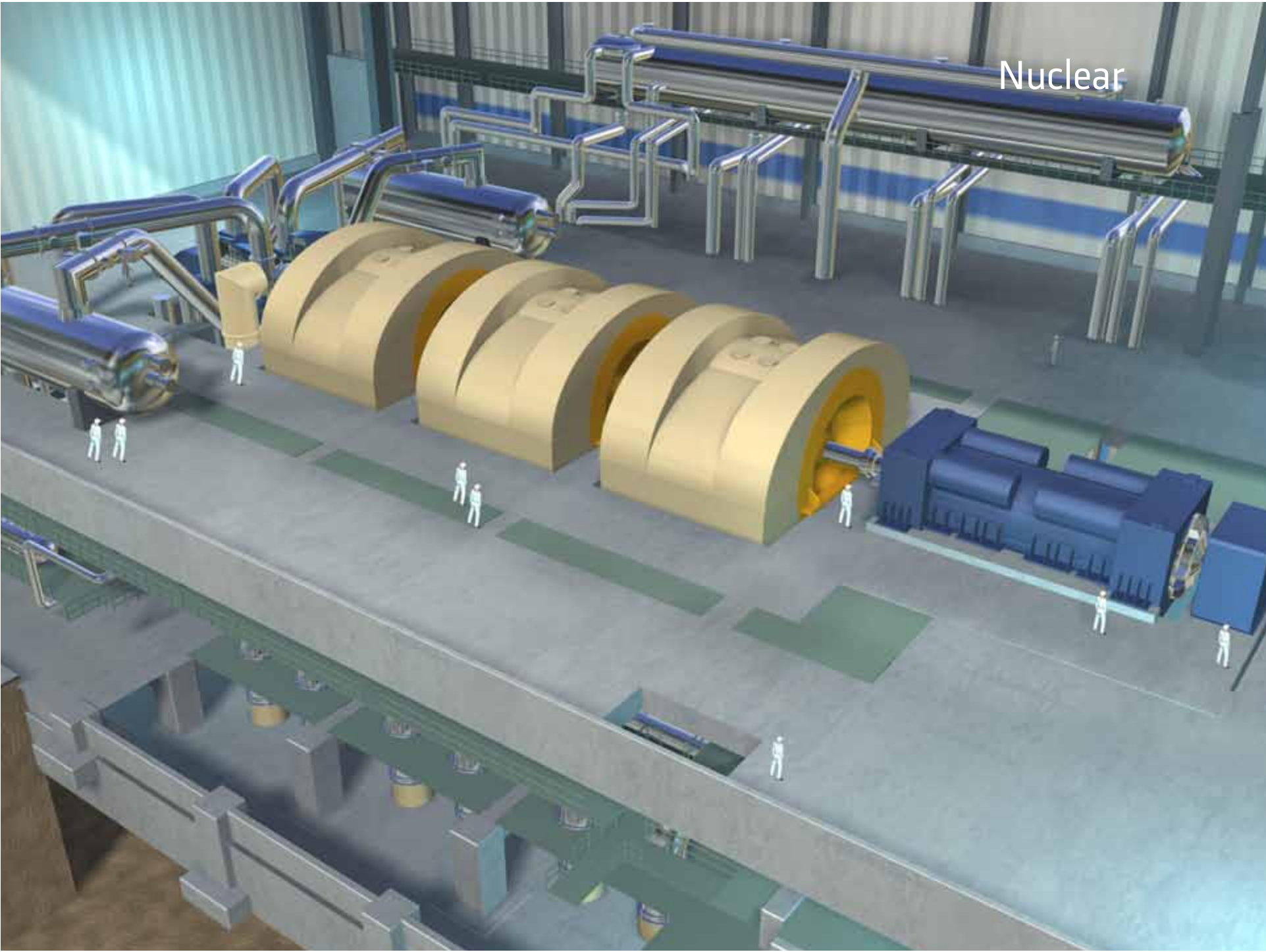

Biomass



# Retrofit

## Arnot case study



### Eskom needs:

- Modernisation and life extension for **6 units** (350MWe) of more than 30 years old
- Generation capacity (peak margins, base-load addition)
- Minimal outage time and cost

### Alstom delivers (3 units to date):

- Gross **output per unit increased** from 350MWe to over 400MWe
- **Short timescales** with quick MWe to the grid system
- **Extending plant lifetime by 20yrs** in an economically and environmentally viable manner (**60% NOx reduction**)

# Roadmap: time-to market targets

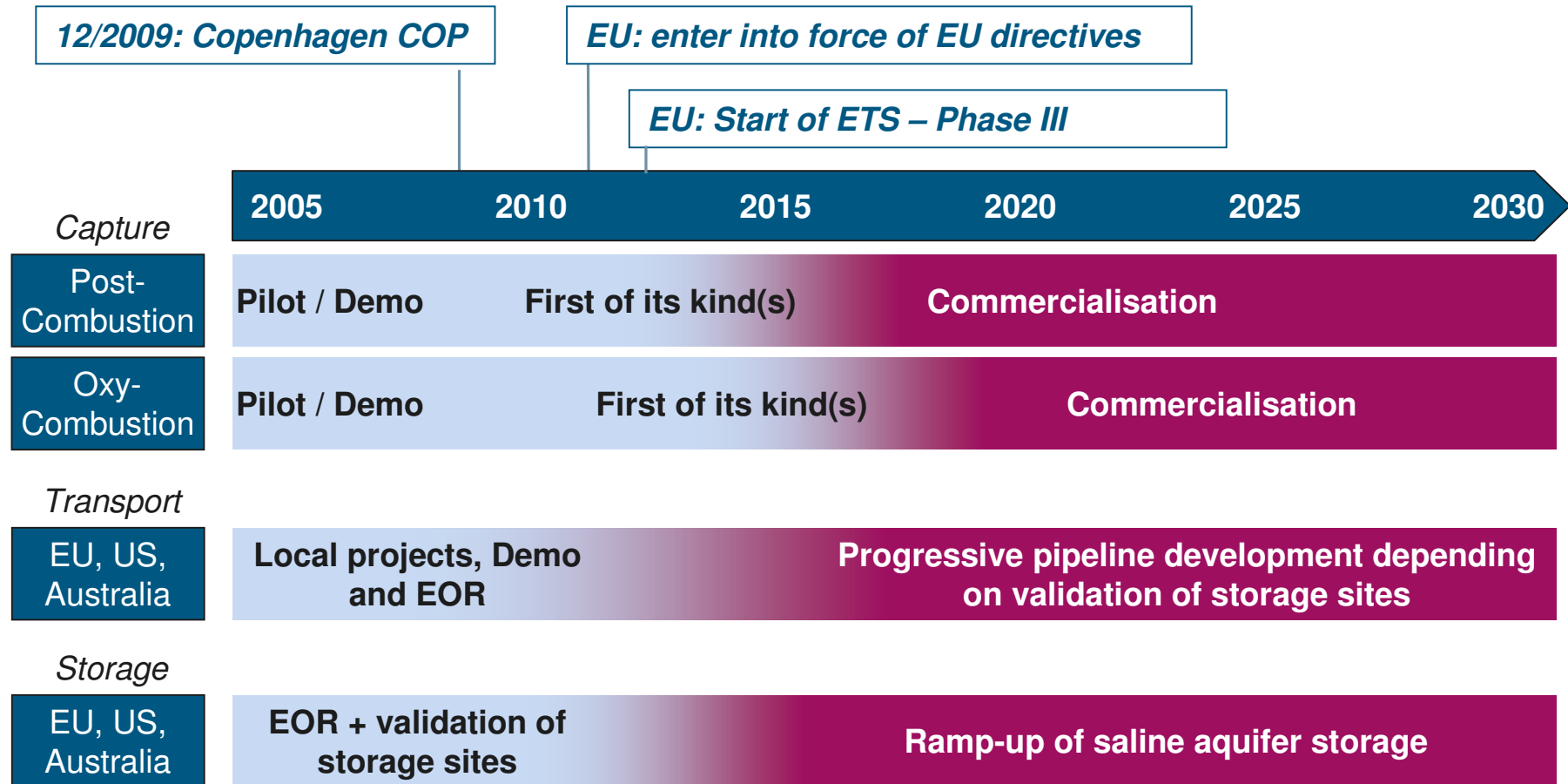

# CoE of low to zero carbon power generation

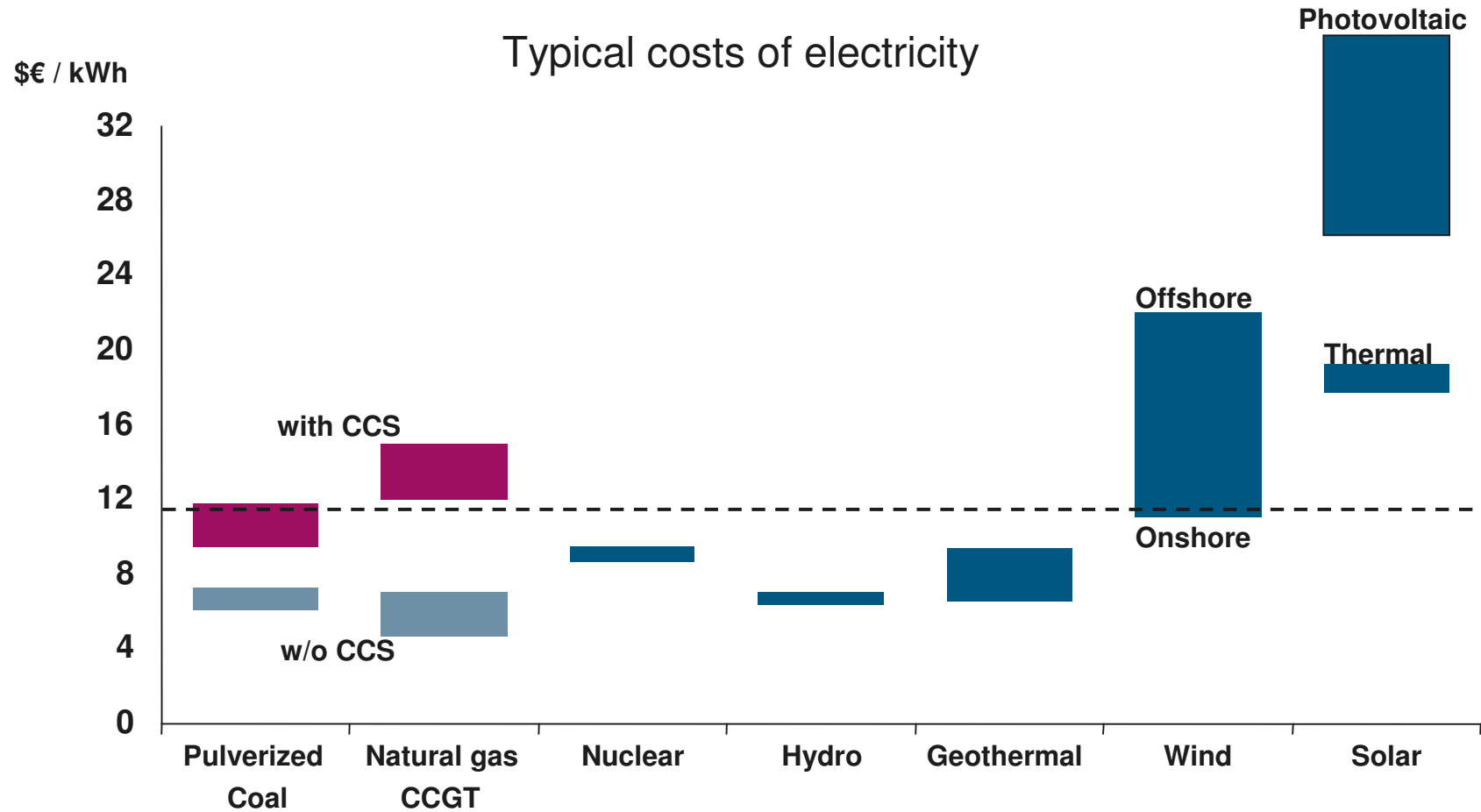

Note: Coal capacity factor of 85%; Gas capacity factor of 65%; Fuel costs: 1.7\$/mmBtu for coal, 4.0\$/mmBtu for gas  
Source: Alstom Analysis

CCS is already competitive with wind



**Clean Power Today !**

**Today we provide the cleanest air solutions**

- for new plants
- for the installed base

**ALSTOM**

[www.alstom.com](http://www.alstom.com)

**ALSTOM**